

ACTIVITY WORKBOOK

FOR

STANDARD - XII (NEW SYLLABUS)

MAHARASHTRA STATE BOARD

INSIDE

TEXTUAL CONTENT

PROSE

POETRY

WRITING SKILL

NOVEL

NON TEXTUAL PASSAGES

OTHER WRITTEN COMMUNICATION

GRAMMAR

ORAL TEST

ACTIVITY SHEET FORMAT

MODEL ACTIVITY SHEET FOR THE FIRST TERM EXAM

MODEL ACTIVITY SHEET FOR THE BOARD EXAM

WRITTEN BY

PROF. TUSHAR CHAVAN

RASHTRIYA JUNIOR COLLEGE,
CHALISGAON, DIST. JALGAON
CONTACT NO. 9850737199

**Book contains activities as per the HSC Board New Activity Sheet
Pattern.**

All answers are also available in the 'Answer Key' Section.



- **Prof. Tushar Chudaman Chavan** from Rashtriya Junior College, Chalisgaon, Dist. Jalgaon
- H.O.D. - English dept. at Rashtriya Jr. College, Chalisgaon
- Work as RP :-
 - Std. fourth Smart PT, in 2003.
 - Upgraded New Syllabus of English (Class XI and XII) in 2013.
 - Senior grade scale in service teachers' training at Nashik in 2017.
 - New evaluation pattern Std. XI in 2019
- Writer-'Activity Work Book for Std. XI-English'.
- Developed a resourceful blog of English subject for the teachers and students of Std. XI and XII.
- Developed result software for Class XI, Attendance sheets and Tax calculations sheets.
- Created ppts, pdfs and videos of the Text topics, Grammar, Online tests, Vocabulary and Writing skill topics.
- Participated in CCRT, Delhi 'Orientation Course for teachers' during 22 January 2018 to 10 February 2018 at the regional center of CCRT Udaipur, Rajasthan
- You Tube Channel - 'Learn With Tushar Chavan'
- Blog link : <https://juniorcollegeteacher.blogspot.com>
- Contact No. 9850737199
- Address:- 'Dhanai', Behind Senior Tyre, Bhadgaon Road, Takli P.C. Chalisgaon, Dist. Jalgaon

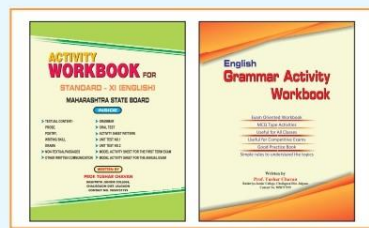
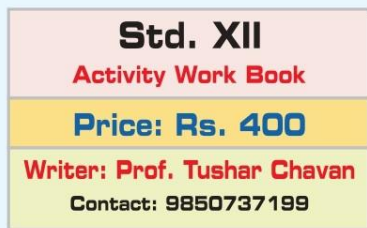

+

Book Price Rs. 400 + Courier Rs. 50 Total- Rs. 450

Discounted price is applicable on buying 25 or more books. Contact. 9850737199

Tushar Chavan's Book Series -

Activity Workbook For Std. XII English Yuvakbharati

(मराठी आवृत्ती)

By: - Prof.Tushar Chavan
Rashtriya Jr. College, Chalisgaon
Dist. Jalgaon

Virtual Free Resource are available at:

<https://juniorcollegeteacher.com>

<https://juniorcollegeteacher.blogspot.com>

You tube channel: 'Learn With Tushar Chavan'

<https://englishfortenthclass.blogspot.com>

<https://learnwithtusharchavan.blogspot.com>

Contact No. 9850737199

Price: Rs. 400

INDEX

Sr.	Topic Name	Page	Key	Sr.	Topic Name	Page	Key
Section – I (Prose)				Section – IV (Genre – Novel)			
1.1	An Astrologer's Day – R. K. Narayan	5	246	4.1	History of Novel	197	331
1.2	On Saying "Please" – Alfred Georg Gardiner	18	252	4.2	To Sir, with Love – E. R. Braithwaite	203	334
1.3	The Cop and the Anthem - O'Henry	31	257	4.3	Around the world In Eighty Days – Jules Gabriel Verne	209	338
1.4	Big Data – Big Insights	42	262	4.4	The Sign of Four – Sir Arthur Ignatius Conan Doyle	216	342
1.5	The New Dress – Virginia Woolf	55	267	Other Written Communication			
1.6	Into the Wild – Kiran Purandare	72	274		1) E – Mail Writing	222	346
1.7	Why We Travel – Siddarth Pico Raghavan Iyer	88	280		2) Report Writing	226	350
1.8	Voyaging Towards Excellence- Achyut Godbole	105	286		3) Framing Interview Questions	228	353
Section – II (Poetry)					4) Speech Writing	231	356
2.1	Song of the Open Road: Walt Whitman	122	292		5) Compering	233	360
2.2	Indian Weavers: Sarojini Naidu	130	296		6) Expansion of Ideas	234	362
2.3	The Inchcape Rock: Robert Southey	136	299		7) Blog Writing	235	365
2.4	Have You Earned Your Tomorrow: E. A. Guest	145	303		8) Review Writing	237	370
2.5	Father Returning Home: Dilip Chitre	150	306		9) Appeal Writing	238	372
2.6	Money: William H. Davies	158	310	A	Spot the error (See on various pages in prose section)		
2.7	She Walks in Beauty: Lord Byron	165	313	B	Oral Exam – Test Paper with Answer	379	
2.8	Small Towns and Rivers: Mamang Dai	170	315	C	Activity Sheet Format- First Term	381	
Section – III (Writing Skill)				D	First Term- Model Activity Sheet	382	
3.1	Summary Writing	176	317	E	Activity Sheet Format- Board Exam	387	
3.2	Do schools Really Kill Creativity? (Mind Mapping)	184	320	F	Board Exam- Model Activity Sheet	390	
3.3	Note – Making	188	323	G	Non-Textual Grammar	396	
3.4	Statement of Purpose	189	324		Various sentences for different Grammar topics with answers.		
3.5	Drafting a Virtual Message	191	326				
3.6	Group Discussion	195	329				

Acknowledgements: -

I express my deep sense of gratitude for the following persons who helped me to make my workbook perfect.

- 1) Prof. B.G.Badgujar, Ex. Principal, Rashtriya Junior College, Chalisgaon Dist. Jalgaon
Ex. Member of Board of Studies, Maharashtra State Board, Pune
- 2) Prof. Sachin Nikam, Rashtriya Junior College, Chalisgaon Dist. Jalgaon

I am grateful to all the teachers who are on my various 'whats app' groups and inspire me to do creative work. I always get a good help of the resources which they share.

- Prof. Tushar Chavan, Rashtriya Junior College, Chalisgaon Dist. Jalgaon

ऑक्टोव्हीटी वर्क बुक विषयी:-

१) Activities च्या मराठी भाषांतराचा समावेश. २) नवीन शब्दांचे मराठीत अर्थ. ३) गद्य पाठ व कादंबरी यांचा मराठीत सारांश. ४) पद्य पाठाचे मराठी रुपांतर. ५) सर्व activities चे आदर्श उत्तरे Answer Key सेक्शन मध्ये उपलब्ध. ६) Writing Skill मध्ये आदर्श उत्तरे कशी लिहावीत याचे मार्गदर्शन ७) बोर्ड परीक्षेच्या प्रश्नपत्रिकेचा आराखडा समाविष्ट ८) सहामाही व बोर्ड परीक्षा यासाठी आदर्श प्रश्नपत्रिका/कृतिपत्रिकेचा समावेश. ९) क्यू.आर. कोडच्या माध्यमातून व्हिडीओ, ऑनलाईन टेस्ट व अन्य माहिती उपलब्ध. स्कॅन करा व अभ्यास करा.

Important Instructions

- 1) Read the passage carefully and write the answers of the activities.
- 2) Check your responses by referring the 'Answer Key'.
- 3) The activities given in other written communication skill section are not completion activities. In the board exam, only hints will be given to write answers. Here in the workbook completion activities are given only for the practice of students. After sufficient practice, students can write the answers in their own words. To reduce the number of pages, in the writing skill section suggestion is given to the students to write answers in their notebooks. See more activities by scanning the QR codes given on various pages.
- 4) Some of the writing skill topics needed answers in the specific templates. So here simple and good templates are given. Use those templates in the exam to write answers.
- 5) For more resources for std. XII English, visit the following website and You tube channel regularly:

<https://juniorcollegeteacher.com>

You tube Channel: 'Learn With Tushar Chavan'

Section I - Prose

1.1 An Astrologer's Day

कथेचा सारांश: -

'एका ज्योतिषाचा दिवस' ही एका अशा ज्योतिषाची कहाणी आहे जो चिंचेच्या वृक्षाखाली आपला व्यवसाय चालवित होता. त्याने दुपारच्या सुमारास आपले काम सुरू केले. सर्वप्रथम आपली व्यावसायिक उपकरणे त्याने पसरविली, ज्यात एक डझन कवड्या, त्यावर अस्पष्ट गूढ आकृत्या असलेला कपड्याचा चौरस तुकडा, एक नोटबुक आणि पाल्मीरा लेखनाचे बंडल यांचा समावेश होता. त्याच्या कपाळावर पवित्र राख आणि शेंदूर चमकत होते. त्याचे मिशा काळ्या होत्या आणि डोळे चमकणारे होते. परिणाम व्हावा म्हणून त्याने डोक्यावर भगव्या रंगाची पगडीही घातली होती. तो अशा ठिकाणी बसला होता जिथे सर्व प्रकारचे लोक नेहमी येत असत. रस्त्याच्या दोन्ही बाजूंना अनेकविध प्रकारचे व्यवसाय व उद्योगधंदे चालत असत. त्याच्या जवळ शेंगदाणे विक्रेता त्याच्या मालाला वेगवेगळे नाव देऊन मोठ्याने ओरडत असे. त्याच्या शेंगदाण्यांना तो कधी 'बॉम्बे आईस्क्रीम' म्हणून तर कधी 'दिल्ली बदाम' किंवा 'शाही मेजवानी' म्हणत असे. लोकही त्याच्याकडे गर्दी करीत असत. यातील बरीचशी गर्दी ज्योतिष्याकडे रेंगाळत असे. जेव्हा अंधार पडायचा तेव्हा त्याला शेजारच्या शेंगदाणा विक्रेत्याकडून प्रकाश मिळायला लागायचा. नगरपालिकेने उजेडाची सोय केलेली नव्हती.

ज्योतिष्याने कोणताही विचार किंवा योजना न करता आपले गाव सोडले होते. जर तो तेथेच राहिला असता तर त्याने आपल्या पूर्वजांसारखेच काम: म्हणजे शेती करणे, लग्न करून संसार करणे आणि आपल्या वडिलोपार्जित घरात राहणे इ. केले असते. त्याच्याकडे प्रशिक्षणाची कमतरता असूनही, त्याच्याकडे चलाखपणा व धूर्तपणा होता. मानवी चिंतांची कारणे त्याला माहिती होती. लग्न, पैसा आणि मानवी संबंधांचे पेच ही कारणे समस्यांची असतात हे तो जाणून होता. म्हणूनच तो आपल्या ग्राहकांना खात्रीने प्रश्नांची उत्तरे देऊ शकत असे. प्रदीर्घ अभ्यासामुळे त्याची समज आणखी तीव्र झाली होती. पाच मिनिटातच ग्राहकाची समस्या तो जाणून घेत असे. प्रत्येक प्रश्नाचे तो ३ पै (जुने चलन) घेत असे. समोरची व्यक्ती कमीतकमी दहा मिनिटे बोलल्याशिवाय तो आपले तोंड उघडत नसे. त्यामुळे त्याला त्या व्यक्तीला देण्यासाठी अनेक उत्तरे व सल्ले मिळविता येत असत. ग्राहकाचा तळहात पाहून तो म्हणो, "तुमच्या कष्टांच्या तुलनेत हवे तेवढे यश तुम्हाला अनेक बाबतीत मिळत नाही." तेव्हा दहा पैकी नऊ तरी सहमत होत. किंवा तो विचारी, "तुमच्या कुटुंबात दूरच्या नात्यात अशी एखादी महिला आहे का जिचे तुमच्याशी सलोख्याचे संबंध नाहीत?" किंवा "तुमचे बहुतेक त्रास तुमच्या स्वभावामुळे होत आहेत अर्थात शनि या ठिकाणी असतांना तुम्ही वेगळे कसे असू शकणार म्हणा? तुमचा स्वभाव उतावळा आहे आणि तुमचे बाह्यस्वरूप कठोर वाटते." या अशा बोलण्यामुळे लोक लगेच खुश होत असत.

एकदा दिवसाची कामे पूर्ण करण्यापूर्वी एका व्यक्तीशी ज्योतिषाची चकमक झाली. आपला शत्रू सापडेल की नाही या प्रश्नाचे समाधानकारक उत्तर त्या माणसाला घ्यायचे होते. त्या अंधुक प्रकाशात ज्योतिषाने त्याला आपला शत्रू म्हणून ओळखले. तो माणूस हाच होता ज्याला ज्योतिषाने चाकू मारला होता व मरण्यासाठी विहिरीत ढकलले होते. ज्योतिषाने त्याच्याबरोबर सौदा केला. आठ आणे रक्कम देण्याचे त्या माणसाने मान्य केले मात्र जर चुकीचे उत्तर निघाले तर दुप्पट रक्कम द्यावी लागणार होती. ज्योतिष्याने त्याच्या प्रश्नांना अशी खात्री पटणारी उत्तरे दिली की तो माणूस पूर्णपणे समाधानी झाला. ज्योतिषाने त्याला सांगितले की त्याच्या छातीत एकदा सुरा खुपसला गेला होता तसेच त्याला शेताजवळच्या विहिरीत मरायला सोडून दिले होते. त्याचे नाव गुरु नायक आहे हेही त्याने सांगितले. आपला शत्रू कधी सापडेल याविषयी ज्योतिषाने

त्याला सांगितले की त्याचा शत्रू एका लॉरीखाली दबला गेला आहे व त्याचा मृत्यू झाला आहे. त्यामुळे तो त्याला भेटणार नाही. आता आयुष्यात कोणताही धोका होऊ नये म्हणून त्याने कधीही दक्षिणेकडे प्रवास करू नये. अशा प्रकारे ज्योतिषाने त्याला निरोप दिला आणि त्या शत्रूपासून स्वतःची सुटका करून घेतली.

घरी पोहोचल्यावर ज्योतिषाने आपल्या पत्नीला सांगितले की तो ज्याला त्याने ठार केले आहे असे वाटत होते तो जिवंत आहे. त्याच्या डोक्यावर गुन्हा केल्याचे एक मोठे ओझे होते. त्याने तिला मागील घटना सांगितली. यानंतर त्याने सुटकेचा निश्वास सोडला आणि तो झोपून गेला.

Activity Sheet No.1

Q. Read the extract and complete the activities given below.

(12)

Punctually at midday, he opened his bag and spread out his professional equipment, which consisted of a dozen cowrie shells, a square piece of cloth with obscure mystic charts on it, a notebook and a bundle of palmyra writing. His forehead was resplendent with sacred ash and his eyes sparkled with a sharp abnormal gleam which was really an outcome of a continual searching look for customers, but which his simple clients took to be a prophetic light and felt comforted.

The power of his eyes was considerably enhanced by their position—placed as they were between the painted forehead and the dark whiskers which streamed down his cheeks: even a half-wit's eyes would sparkle in such a setting. To crown the effect, he wound a saffron-colored turban around his head. This color scheme never failed. People were attracted to him as bees are attracted to cosmos or dahlia stalks. He sat under the boughs of a spreading tamarind tree which flanked a path running through the Town Hall Park.

It was a remarkable place in many ways: a surging crowd was always moving up and down this narrow road morning till night. A variety of trades and occupations was represented all along its way: medicine-sellers, sellers of stolen hardware and junk, magicians and, above all, an auctioneer of cheap cloth, who created enough din all day to attract the whole town. Next to him in vociferousness came a vendor of fried groundnuts who gave his ware a fancy name each day, calling it Bombay Ice-Cream one day, and on the next Delhi Almond, and on the third Raja's Delicacy, and so on and so forth, and people flocked to him.

A1. Web

(2)

Complete the web with the professional equipment mentioned in the extract.

खालील वेब मध्ये ज्योतिषाच्या वस्तूंची नावे लिहा.

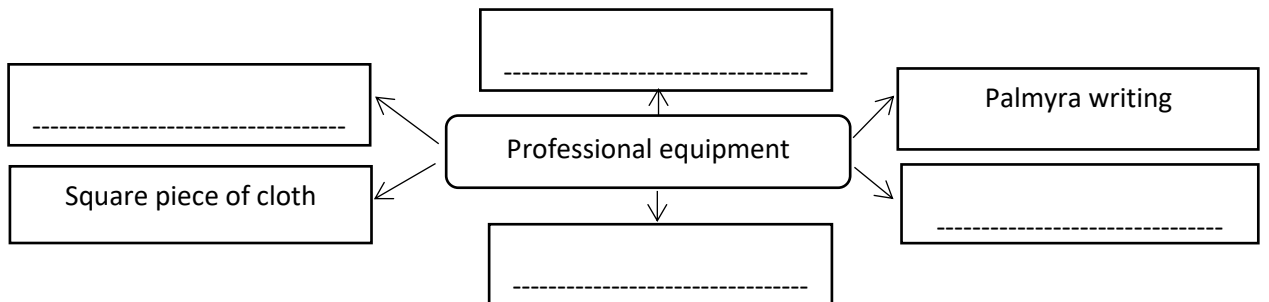

A2. Describe

(2)

Describe the marketplace given in the extract in 50 words. बाजाराचे 50 शब्दात वर्णन करा.

Answer: - -----

A3. Find (2)

The prophet made special arrangements to attract people. Find its proof from the extract
ज्योतिषाने लोकांना आकर्षित करण्यासाठी केलेल्या उपाययोजनांचा पुरावा द्या.

Answer: - -----

A4. Personal Response (2)

Write in 50 words about the career you like to choose in your life.

तुम्हाला आवडणाऱ्या करियर ची 50 शब्दात माहिती द्या.

Answer: - -----

A5. Language Study (Do as directed) (2)

1) This color scheme never failed.

(Choose the correct alternative showing affirmative sentence having the same meaning given here)

- i) This colour scheme always failed. ii) This colour scheme always successful.
iii) This colour scheme was always successful. iv) This colour scheme is always successful.

Answer: - -----

2) To crown the effect, he wound a saffron-colored turban around his head.

(Choose the correct alternative to rewrite the given sentence as a compound sentence)

- i) He wound a saffron-colored turban around his head and crowned the effect.
ii) He wound a saffron-colored turban around his head to crown the effect.
iii) He wound a saffron-colored turban around his head which crowned the effect.
iv) He wound a saffron-colored turban around his head while crowning the effect.

Answer: - -----

A6. Vocabulary (2)

Match the words given in 'A' with their meanings given in 'B'. (जोड्या लावा)

A	B
1) punctually	a) unclear
2) remarkable	b) holy
3) obscure	c) striking
4) sacred	d) at the proper time

A	B
1) punctually	
2) remarkable	
3) obscure	
4) sacred	

All model answers are available in the Answer Key section.

Features of the New Activity Work Book- Std. XII:-

- 1) Total Pages = 400 (Big Book- All in One Book)
- 2) Variety of activities on textual topics-
 - a) Prose
 - b) Poetry
 - c) Writing Skill
 - d) Novel
- 3) Various activities on Other Written Communication-
Total 09 Topics
- 4) Model First Term Exam Activity Sheet-
Marks = 50
- 5) Model Board Exam (Annual Exam) Activity Sheet-
Marks = 80
- 6) Model Oral test paper-
Marks = 20
- 7) Examples of Spot the Error
See it on the half pages of prose topics.
- 8) Answer Key of all the topics
See it at the Last Pages

Other Features:-

- A bigger book than the books in the market. See pages of other books available in the market. Only 200 to 250 pages are there. This book has 400 pages.
- Its good practice book for the students.

1) Summary of prose, poetry and novel is given in English and Marathi.

इंग्रजी व मराठी मध्ये गद्य, पद्य व कादंबरीचा सारांश दिलेला आहे.

2) Marathi translation of new words is included.

नवीन शब्दांचे मराठीत अर्थ दिलेले आहेत.

3) Non - textual grammar sentences are added.

टेक्स्ट पुस्तकाबाहेरील काही ग्रामर ची वाक्ये समाविष्ट केली आहेत.

All Writing Skill Topics are available with Model Answers. Click below words to get it online free.

Writing Skill

Prof. Tushar Chavan

[Framing Interview Questions](#)

[Mind Mapping](#)

<u>Drafting a Virtual Message</u>	<u>E- Mail Writing</u>
<u>Group Discussion</u>	<u>Expansion Of Idea</u>
<u>Speech Writing</u>	<u>Report Writing</u>
<u>Blog Writing</u>	<u>Film Review</u>
<u>Compering</u>	<u>Book Review</u>
<u>Leaflet/Appeal</u>	<u>Speech Writing</u>
<u>Statement of Purpose</u>	<u>Summary Writing</u>



- New evaluation pattern is activity based. It is essential that students should get ample practice of various activities. It will boost their confidence to deal with the activities and they will get maximum marks in the exam.
- Good simple templates are given for the other written communication activities. Students can use them in the board exam.
- Most of the books in the market do not provide the other written communication examples. Here they are included with answers.
- Oral test paper is also added to take practice of the oral exam.
- Model First term Exam Activity and Annual Exam Activity Sheet are now added. They give good knowledge of the new pattern.
- Activity sheet pattern for the First Term Exam and Annual (Board) Exam are also added.
- More examples are included in Writing Skill topics.
- Guidelines are given in both English and Marathi for writing the answers of Writing Skill topics.
- Good templates are given for e – mail and blog writing.
- All the activities are given as per the new activity sheet pattern.

Bank Details and Other Information-

Account Holder Name - Tushar Chudaman Chavan

Bank A/C No. 067410110003341

Bank of India, Chalisgaon Dist. Jalgaon

IFSC code : BKID0000674

Mobile No. 9850737199

Please send money to correct account number.

Google pe or Pe Phone Number: 9850737199

Bulk quantity orders will be given good discount. Such orders will be sent only by S.T. courier only.

Contact:

Prof. Tushar Chavan

Rashtriya Junior College

Chalisgaon

Dist. Jalgaon

Phone: 9850737199



Use following digital resources for self-study:

<https://juniorcollegeteacher.com>

<https://juniorcollegeteacher.blogspot.com>

<https://learnwithtusharchavan.blogspot.com>

<https://englishfortenthclass.blogspot.com>

<https://www.youtube.com/c/LearnwithTusharChavan>